

USER MANUAL

WATER-PROOF SENSORLESS BRUSHLESS SPEED CONTROLLER (RTR VERSION)

【FEATURES】

1. Water-proof and dust-proof. The ESC can work under water for a short time.
(Please remove the cooling fan when running car in water, and after running, please make the ESC clean and then dry it to avoid the oxidation to copper connectors)
2. Specially designed for RC car and truck, with excellent start-up, acceleration and linearity features.
3. Drive sensorless brushless motors.
4. 2 running modes ("Forward with brake" mode, "Forward/Backward with brake" mode).
5. Proportional ABS brake function with 4 steps of maximum brake force adjustment, 8 steps of drag-brake force adjustment.
6. 4 start modes ("Punch") from "Soft" to "Very aggressive" to be suitable for different chassis, tires and tracks.
7. Multiple protection features: Low voltage cut-off protection for Lipo or NiMH battery / Over-heat protection / Throttle signal loss protection / Motor blocked protection.
8. Easily programmed with the "SET" button on the ESC or with the LED Program Card.

【SPECIFICATIONS】

Model	WP-S10D-RTR	WP-10BL50-RTR-V4	WP-10BL60-RTR-V4	
Conf./Burst Current	60A/390A	50A/300A	60A/390A	
Motor Type	Sensored / Sensorless Brushless Motor (only in sensorless mode)			
Car Applicable	1/10th Touring Car, Buggy, Truck			
Motor Limit	2S Lipo 6 cells	On-road: $\geq 5.5T$ Off-road: $\geq 9T$ 3650 size motor	On-road: $\geq 8T$ Off-road: $\geq 11T$ 3650 size motor	On-road: $\geq 5.5T$ Off-road: $\geq 9T$ 3650 size motor
	3S Lipo 9 cells NiMH	On-road: $\geq 8.5T$ Off-road: $\geq 13T$ 3650 size motor	On-road: $\geq 11T$ Off-road: $\geq 14T$ 3650 size motor	On-road: $\geq 8.5T$ Off-road: $\geq 13T$ 3650 size motor
Battery	4-9S NiMH, 2-3S LiPo			
BEC Output	6V/2A (Linear mode BEC)	6V/3A (Switch-mode BEC)		
Cooling Fan(Notes 1)	Powered by battery	Powered by the stable BEC voltage of 6V		
Program Port	FAN /PRG Port			
Dimension/Weight	49mm*34mm*35mm / 75g	48.5mm*38mm*32mm / 90g	48.5mm*38mm*32mm / 90g	

Note1:

1)The cooling fan on the WP-S10D-RTR ESC draws amperage directly from the battery pack, and the 5V fan can only work with a 2S LiPo / 4-6S NiMH battery pack. When using a 3S LiPo/7-9S NiMH battery pack, then the fan must be changed into a 7.4V/12V one. The cooling fan on the WP-10BL50-RTR / WP-10BL60-RTR ESC is powered by the built-in BEC, so the 5V fan is OK and there is no need to consider if the input voltage is high or low.

【BEGIN TO USE THE NEW ESC】

1. Connect the ESC, motor, receiver, battery and servo according to the following diagram

"+" and "-" wires of the ESC are connected with the battery pack, and #A, #B and #C are connected with the motor wires. The "SET" button is used for programming the ESC.

The control cable of the ESC (trio wires with black, red and white color) is connected with the throttle channel of the receiver (Usually CH2).

1The #A, #B, #C wires of the ESC can be connected with the motor wires freely (without any order). If the motor runs in the opposite direction, please swap any two wire connections.

Note: You can use the transmitter to set the throttle channel to the

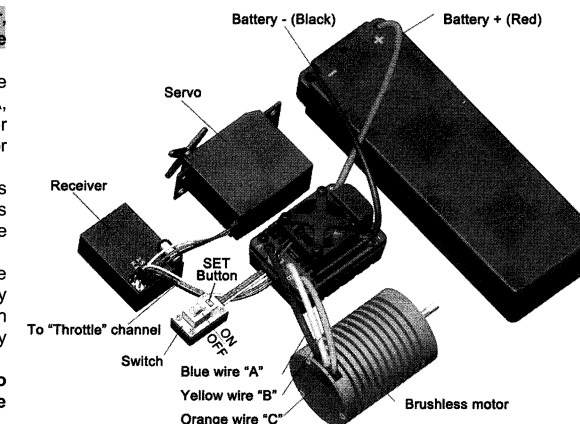

【DECLARATION】

Thanks for purchasing our electronic speed controller (ESC). The power system for RC model can be very dangerous, so please read this manual carefully. In that we have no control over the correct use, installation, application, or maintenance of our products, no liability shall be assumed nor accepted for any damages, losses or costs resulting from the use of the product.

“Reverse” direction, and then the motor will run oppositely. Please calibrate the throttle range again after changing the direction of throttle channel.

2. Throttle Range Setting (Throttle Range Calibration)

In order to make the ESC match the throttle range, you must calibrate it when you begin to use a new ESC, or a new transmitter, or after changing the settings of the neutral position of throttle channel, ATV or EPA parameters, otherwise the ESC cannot work properly.

There are 3 points need to be set, they are the top point of “forward,” backward” and the neutral point.

The following pictures show how to set the throttle range with a Futaba™ transmitter.

- A) Switch off the ESC, turn on the transmitter, set the direction of throttle channel to “REV”, set the “EPA/ATV” value of throttle channel to “100%”, and disable the “ABS” brake function of your transmitter. (Note2)
- B) Hold the “SET” key and then switch on the ESC, when the red LED begins to flash, release the key immediately. (Please check the picture on the right side)

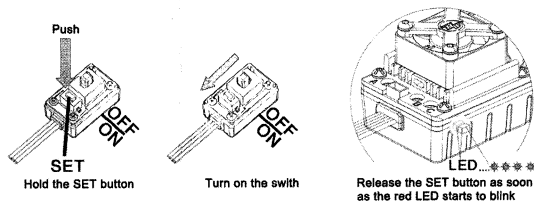

- C) Set the THREE points according to the steps shown in the picture on the right side.
 - 1) Neutral point
 - 2) End point of forward direction
 - 3) End point of backward direction
- D) When the process of calibration is finished, the motor can be started after 3 seconds.

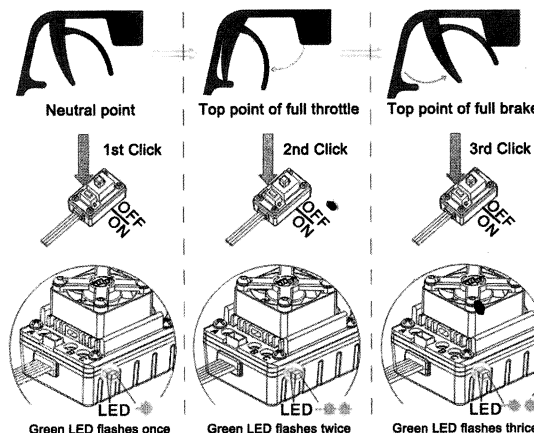

Note2: If you don't release the “SET” key after the red LED begins to flash, the ESC will enter the program mode, in such a case, please switch off the ESC and re-calibrate the throttle range again from step A to step D.

3. The LED Status in Normal Running

- a) When the throttle stick is in the neutral range, neither the Red LED nor the Green LED lights up.
- b) When the car moves forward, the Red LED solidly lights; the Green LED also lights up when the throttle stick is at the top position (100% throttle).
- c) When the car brakes, the Red LED solidly lights; the Green LED also lights up when the throttle stick is at the bottom position and the maximum brake force is set to 100%.
- d) When the car reverses, the Red LED solidly lights.

[ALERT TONES]

- 1. Input voltage abnormal alert tone: The ESC begins to check the input voltage when power on, if it is out of the normal range, such an alert tone will be emitted: “beep-beep-, beep-beep-, beep-beep-” (There is 1 second time interval between every “beep-beep-” tone).
- 2. Throttle signal abnormal alert tone: When the ESC can't detect the normal throttle signal, such an alert tone will be emitted: “beep-, beep-, beep-” (There is 2 seconds time interval between every “beep-” tone).

[PROTECTION FUNCTION]

- 1. Low voltage cut-off protection: If the voltage of a Lipo battery pack is lower than the threshold for 2 seconds, the ESC will cut off the output power. Please note that the ESC cannot be restarted if the voltage of each Lipo cell is lower than 3.5V. For NiMH battery packs, if the voltage of the whole NiMH battery pack is higher than 9.0V but lower than 12V, it will be considered as a 3S Lipo; If it is lower than 9.0V, it will be considered as a 2S Lipo. For example, if the NiMH battery pack is 8.0V, and the threshold is set to 2.6V/Cell, it is considered as a 2S Lipo, and the low-voltage cut-off threshold for this NiMH battery pack is 2.6*2=5.2V.
- 2. Over-heat protection: When the temperature of the ESC is over a factory preset threshold for 5 seconds, the ESC will cut off the output power. You can disable the over-heat protection function for competition race.

- 3. Throttle signal loss protection: The ESC will cut off the output power if the throttle signal is lost for 0.2 second.

[PROGRAM THE ESC]

1. Program Method

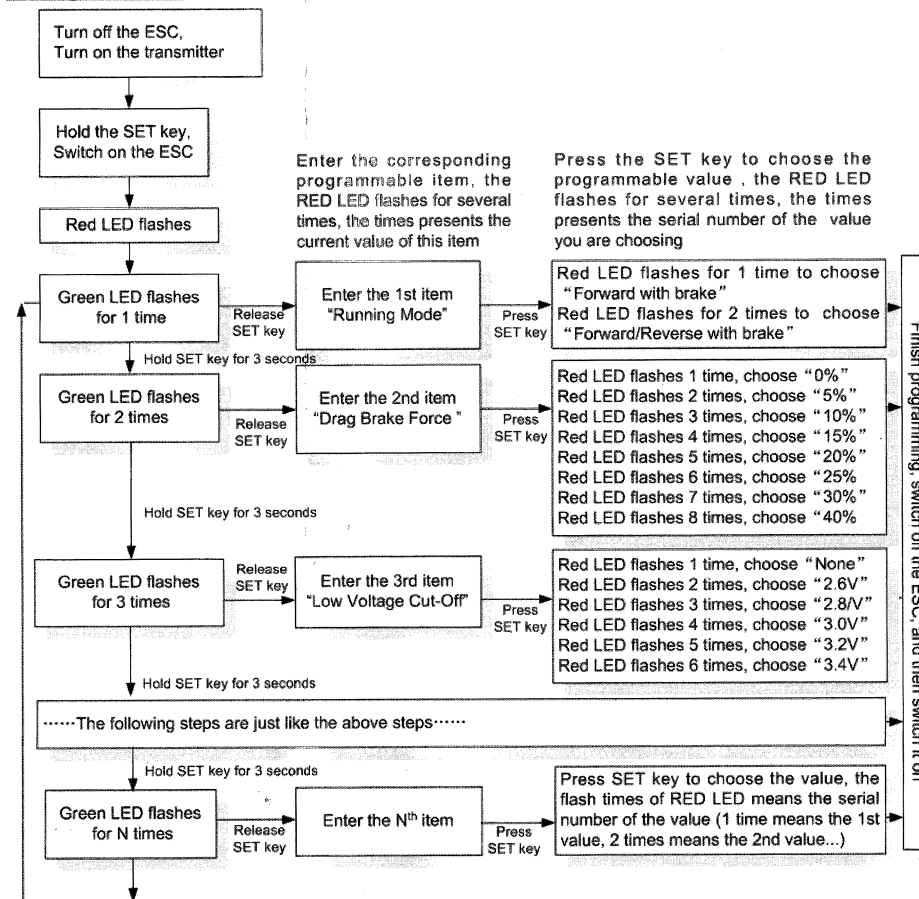

Note:

- ↓ In the program process, the motor will emit “Beep” tone when the LED is flashing.
- ↓ The 5th programmable item is represented by 5 short Beeps (that is, “BBBBB”).
- ↓ For the options of each programmable item, we use a long time flash and long “Beep-” tone to represent number “5”, so it is easy to identify the options with big numbers. For example, if the LED flashes as the following:
 “A long time flash” (Motor sounds “B-”) = The option 5
 “A long time flash + a short time flash” (Motor sounds “B--B”) = The option 6
 “A long time flash + 2 short times flash” (Motor sounds “B---BB”) = The option 7
 “A long time flash + 3 short times flash” (Motor sounds “B----BBB”) = The option 8

2. Programmable Items list

Programmable Items	Programmable Value							
	1	2	3	4	5	6	7	8
1. Running Mode	Forward with Brake	<i>Forward/Reverse with Brake</i>						
2. Drag Brake Force	0%	5%	10%	15%	20%	25%	30%	40%
3. Low Voltage Cut-Off Threshold	Non-Protection	2.6V /Cell	2.8V /Cell	3.0V /Cell	<i>3.2V /Cell</i>	3.4V /Cell		
4. Start Mode (Punch)	Level1 (Soft)	Level2	<i>Level3</i>	Level4 (Very Aggressive)				
5. Maximum Brake Force	25%	50%	<i>75%</i>	100%				

Attention: The italics texts in the above form are the default settings.

3. Programmable Items

3.1. Running Mode: With "Forward with Brake" mode, the car can go forward and brake, but cannot go backward, this mode is suitable for competition; "Forward/Reverse with Brake" mode provides backward function, which is suitable for training.

Note: "Forward/Reverse with Brake" mode uses "Double-Click" method to make the car go backward. When you move the throttle stick from forward zone to backward zone for the first time, the ESC begins to brake the motor, the motor speeds down but it is still running, not completely stopped, so the backward action is NOT happened now. When the throttle stick is moved to the backward zone again (The 2nd "click"), if the motor speed is slowed down to zero (i.e. stopped), the backward action will be occurred. The "Double-Click" method can prevent mistakenly reverse when the brake function is frequently used in steering.

3.2. Drag Brake Force: Set the amount of drag brake applied at neutral throttle to simulate the slight braking effect of a neutral brushed motor while coasting.

3.3. Low Voltage Cut-Off: The function is mainly used to prevent the Lipo battery from over discharging. The ESC monitors the battery's voltage at any time, if the voltage is lower than the threshold, the output power will be reduced to 50% in 2 seconds. Please drive to the side of racing track as soon as possible and then stop the car, the ESC will completely cut off the output power in 10 seconds. The values listed in the table refer to the cut-off threshold for each Lipo cell.

3.4. Start Mode (Also called "Punch"): Select from "Level1 (Soft)" to "Level 4(Very aggressive)" start mode as you like. Please note that if you choose "Level 4(Very aggressive)", you should use good quality battery with powerful discharge ability, otherwise you cannot get the bursting start effect as you want. If the motor cannot run smoothly (that is: the motor is trembling), it may caused by the weak discharge ability of the battery, please choose a better battery or increase the gear rate.

3.5. Maximum Brake Force: The ESC provides proportional brake function. The brake force is related to the position of the throttle stick. Maximum brake force refers to the force when the throttle stick is located at the top point of the backward zone. A very large brake force can shorten the brake time, but it may damage the gears.

4. Reset All Items To Default Values

At any time when the throttle is located in neutral zone (except in the throttle calibration or programming mode), hold the "SET" key for over 3 seconds, the red LED and green LED will flash at the same time, which means each programmable item has be reset to its default value. It needs to be restarted to complete the whole process.

[OPTIONAL ACCESSORIES]

We provide the following optional accessories:

1. Cooling fan (12V): The high voltage fan is an option when you use 3S Lipo or NiMH battery more than 6 cells.

WARNING! Please note the original cooling fan (5V) is only allowed to work with 2S Lipo or 4-6 cells NiMH battery. Please DON'T use it with a 3S Lipo or NiMH battery more than 6 cells.

2. LED Program Card (Digital LED Display)

The LED Program Card is an optional accessory which needs to be purchased separately. It has a friendly user interface. The process of programming the ESC becomes quite easy and fast with this pocket sized device.

Please connect the ESC to LED Program Card via the program port.

Mark: Direction of the airflow and the impeller

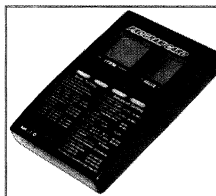
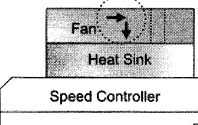

- The program port is multiplexed with the cooling fan port, please disconnect the cooling fan, and then use program cable to connect the fan port of the ESC to the LED program card.

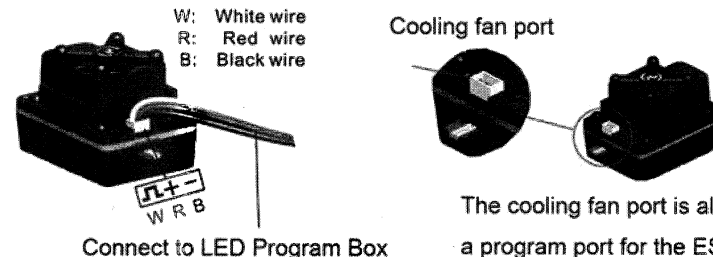

[TROUBLE SHOOTING]

Trouble	Possible Reason	Solution
After power on, motor can't work, no sound is emitted	The connections between battery pack and ESC are not correct	Check the power connections Replace the connectors
After power on, motor can't work, but emits "beep-beep-, beep-beep-" alert tone. (Every "beep-beep-" has a time interval of 1 second)	Input voltage is abnormal, too high or too low.	Check the voltage of the battery pack
After power on, motor can't work, but emits "beep-, beep-, beep-" alert tone. (Every "beep-" has a time interval of about 2 seconds). And the red LED solid lights	Throttle signal is abnormal	Check the transmitter and the receiver Check the wire of the throttle channel
After power on, motor can't work and the red LED blinks very quickly	The neutral point of the throttle channel is changed	Calibrate the throttle range for the ESC again, or adjust the trimmer of throttle channel (on the transmitter) to change the neutral point.
The motor runs in the opposite direction	The wire connections between ESC and the motor need to be changed	Swap any two wire connections between the ESC and the motor.
The motor suddenly stops running while in working state	The throttle signal is lost	Check the transmitter and the receiver Check the wire of the throttle channel
	The ESC has entered the Low Voltage Protection Mode	Replace the battery pack
Random stop or restart or irregular working state	Some connections are not reliable	Check all the connections: battery pack connections, throttle signal wire, and motor connections, etc.
	There is strong electro - magnetic interference in flying field.	Reset the ESC. If the function could not be resumed, you might need to move to another area to run the car.