

THREE VIEW DRAWING

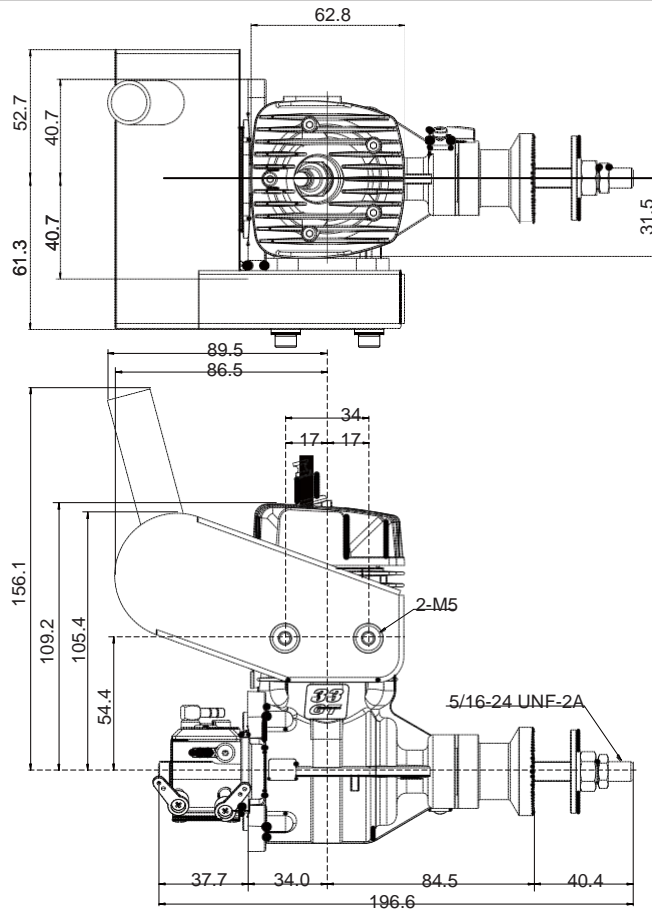

Specifications

■ Displacement	32.98 cc / 2.013 cu.in.
■ Bore	36.0 mm / 1.417 in.
■ Stroke	32.4 mm / 1.276 in.
■ Practical R.P.M.	1,800-8,000 r.p.m.
■ Output	3.9 ps / 3.84 hp / 9,000r.p.m.
■ Weight	984g / 34.57 oz. (Engine)
	160 g / 4.94 oz. (Silencer)

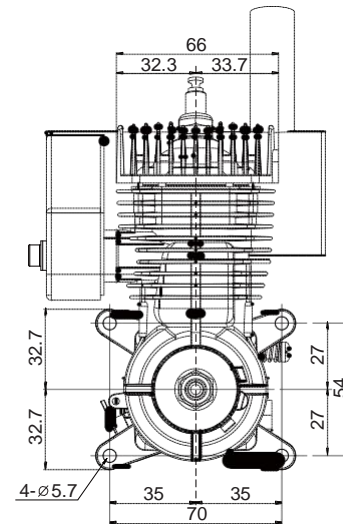

Dimensions (mm)